

NAKAJIMA A2N2 1/48 ABK MODELS

NAVY TYPE 90-II CARRIER-BASED FIGHTER 九〇式二号艦上戦闘機 (A2N2)



General characteristics:

Crew: 1
 Length: 6.183 m
 Wingspan: 9.37 m
 Height: 3.025 m
 Empty weight: 1,045 kg
 Gross weight: 1550 kg
 Powerplant: Nakajima Kotobuki 2 9-cylinder air-cooled radial piston engine
 343-433 kW (460-580 hp)
 Propeller: 2-bladed Hamilton Standart fixed-pitch propeller

Performance:

Maximum speed: 293 km/h
 Cruise speed: 167 km/h
 Range: 500 km
 Endurance: 3 hours
 Service ceiling: 9,000 m
 Time to altitude: 3,000 m in 5 minutes
 45 seconds

Armament

Guns: 2x 7.7 mm machine guns

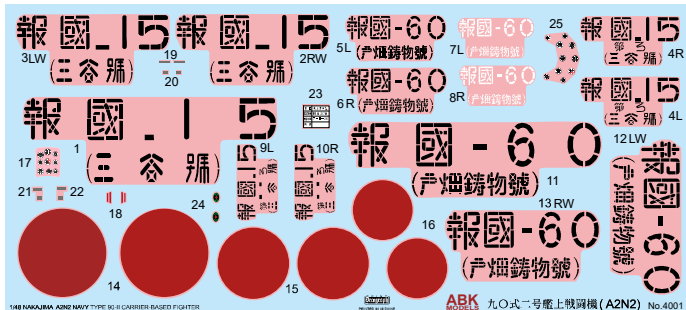

MODEL CONSTRUCTION KIT

Ready to assembly scale models kit.
 Contains part for one model.
 Wingspan: 195 mm
 Fuselage: 129 mm
 Plastic parts: 63

1/48 SCALE No.4001

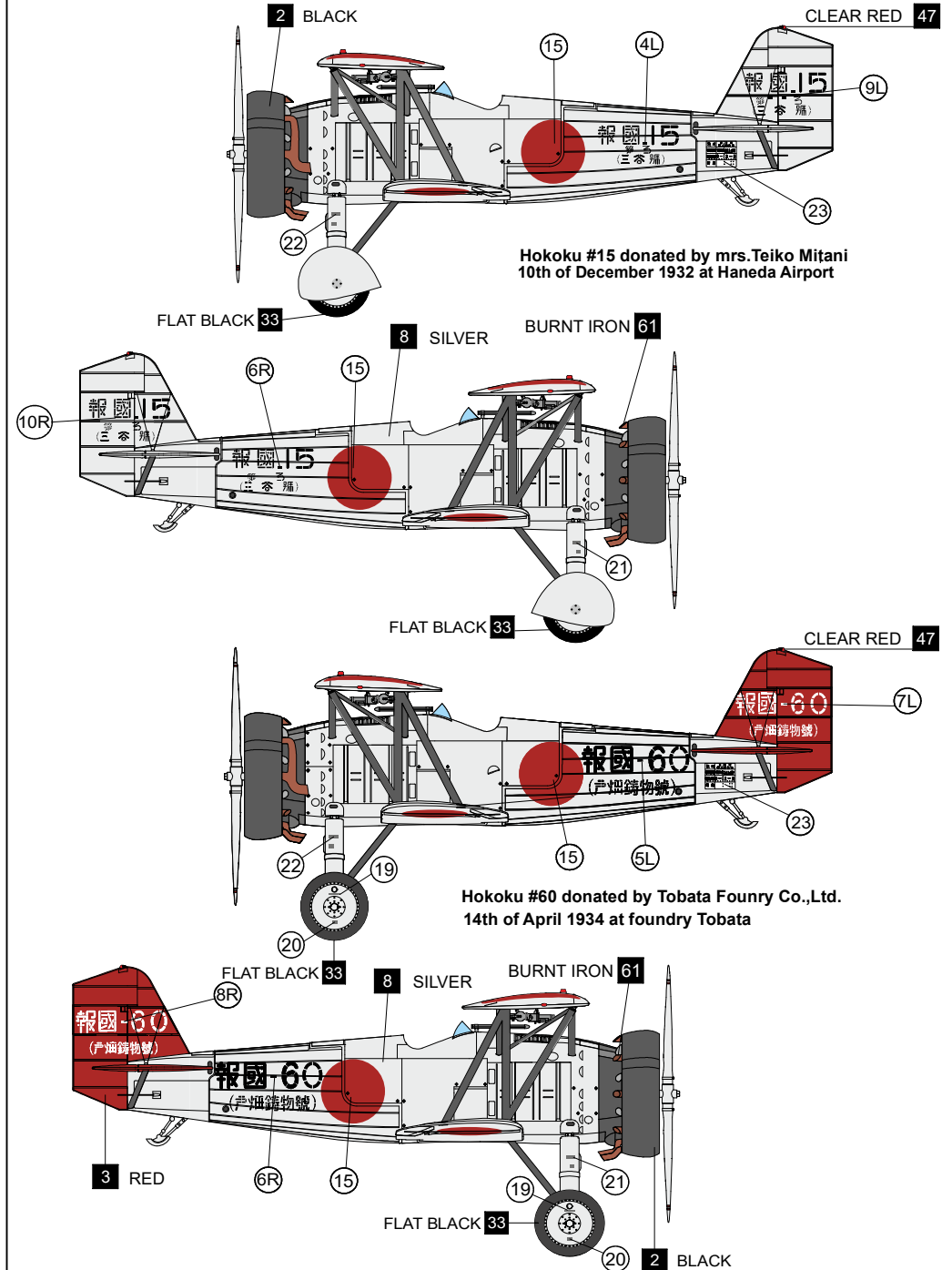

Hokoku #15 donated by Mrs. Teiko Mitani
10th of December 1932 at Haneda Airport

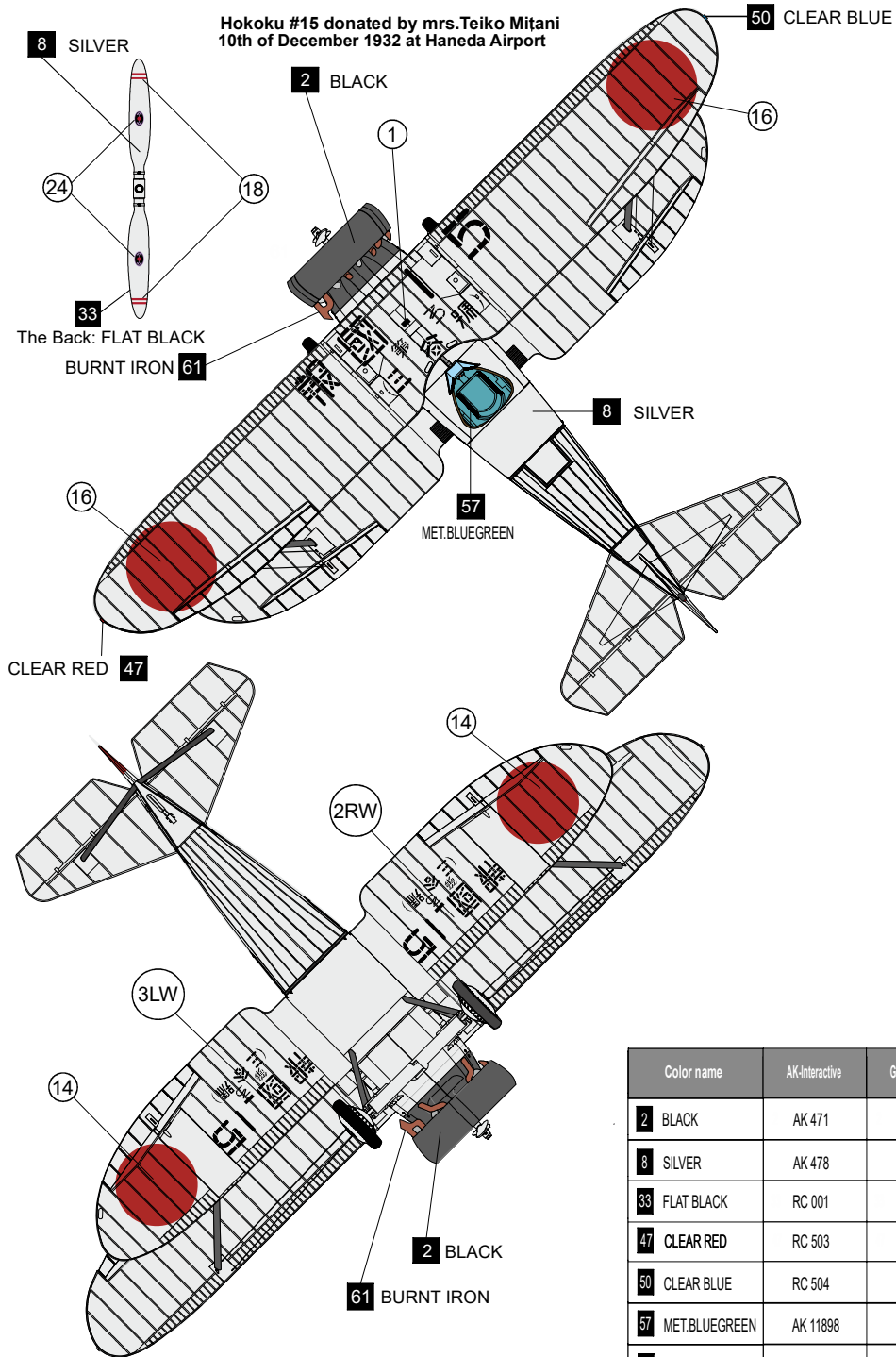

Hokoku #60 donated by Tobata Foundry Co., Ltd.
14th of April 1934 at foundry Tobata

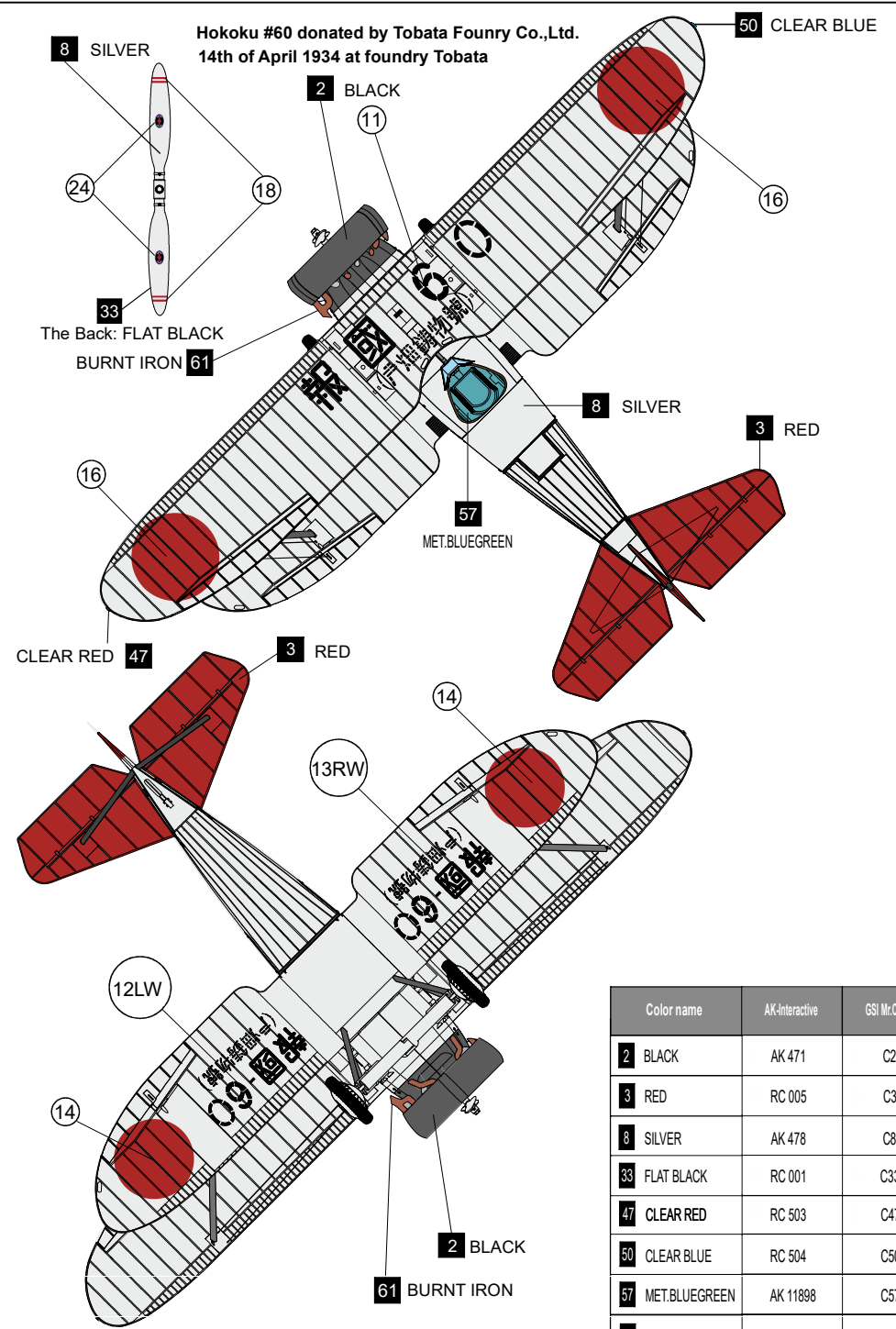

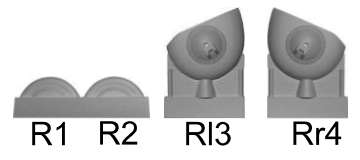
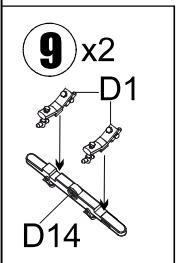
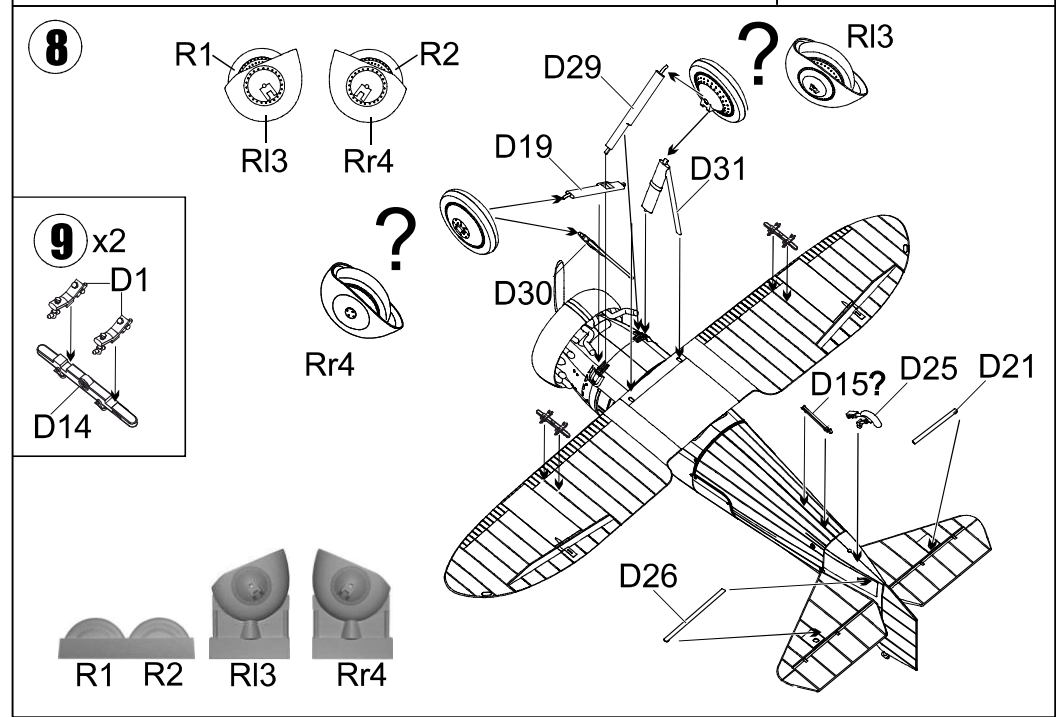
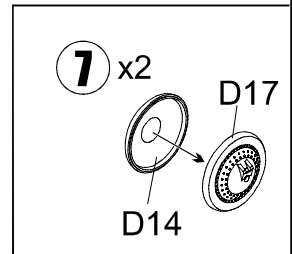
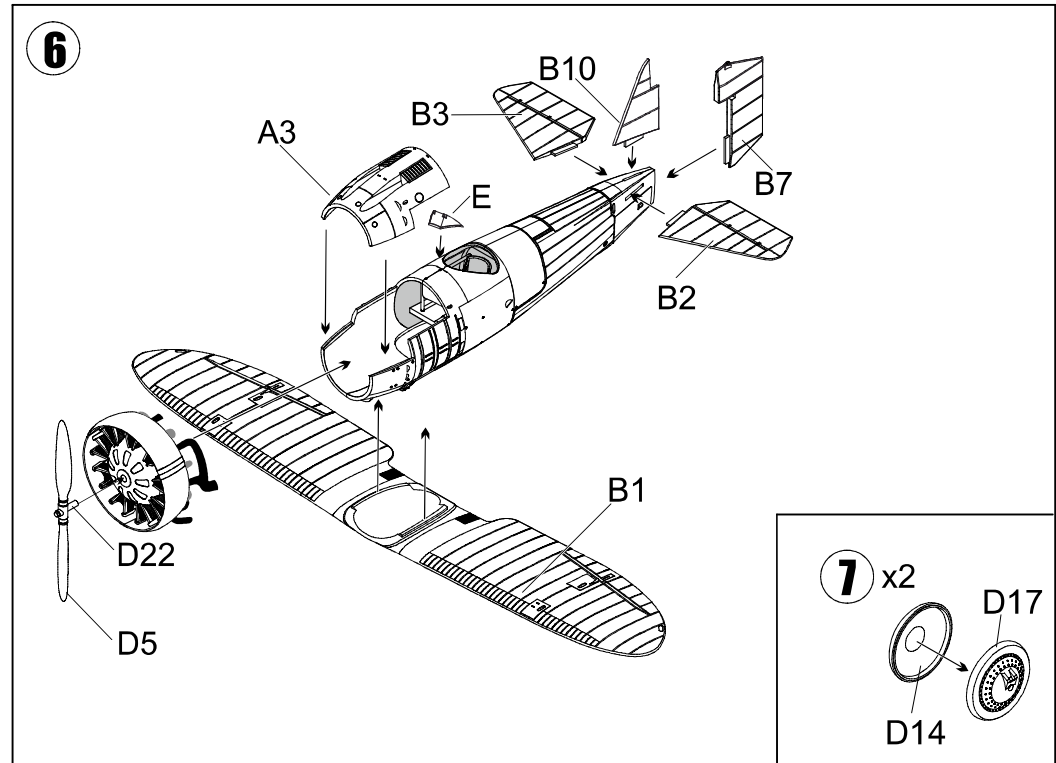
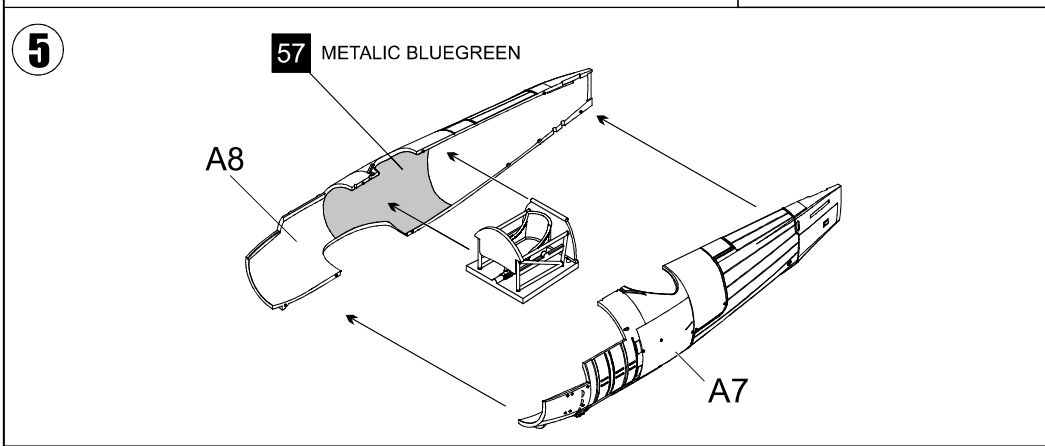
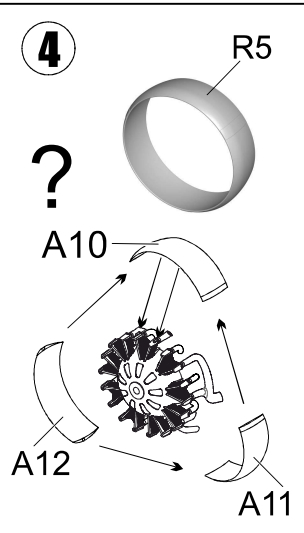
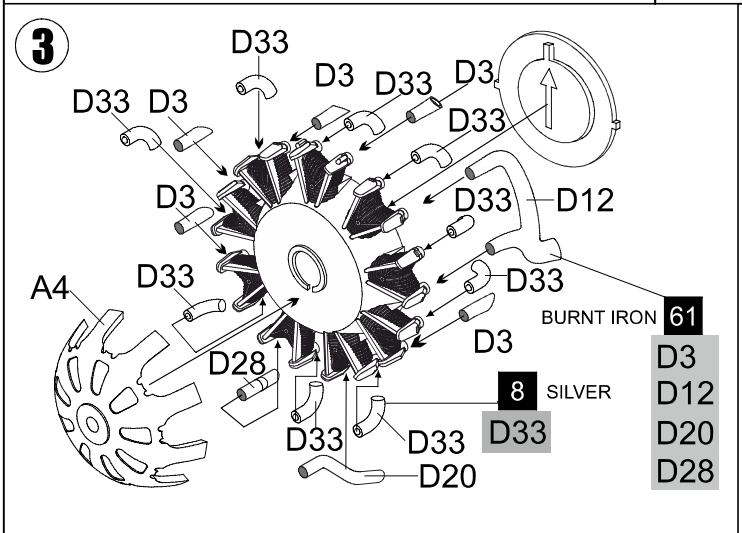
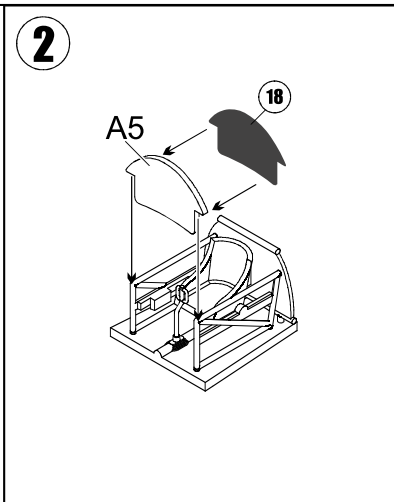
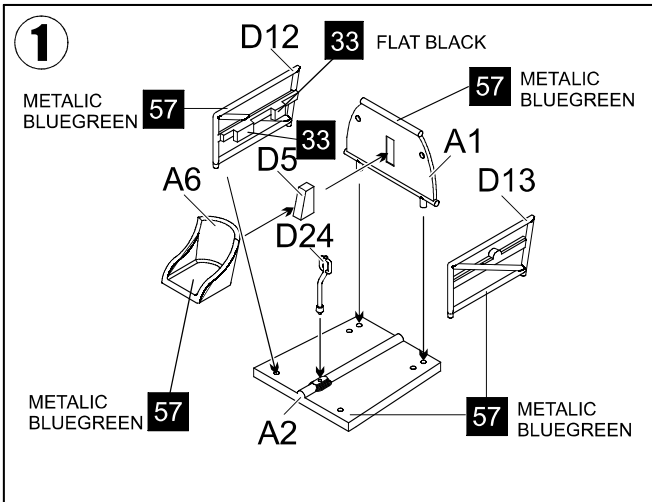

10

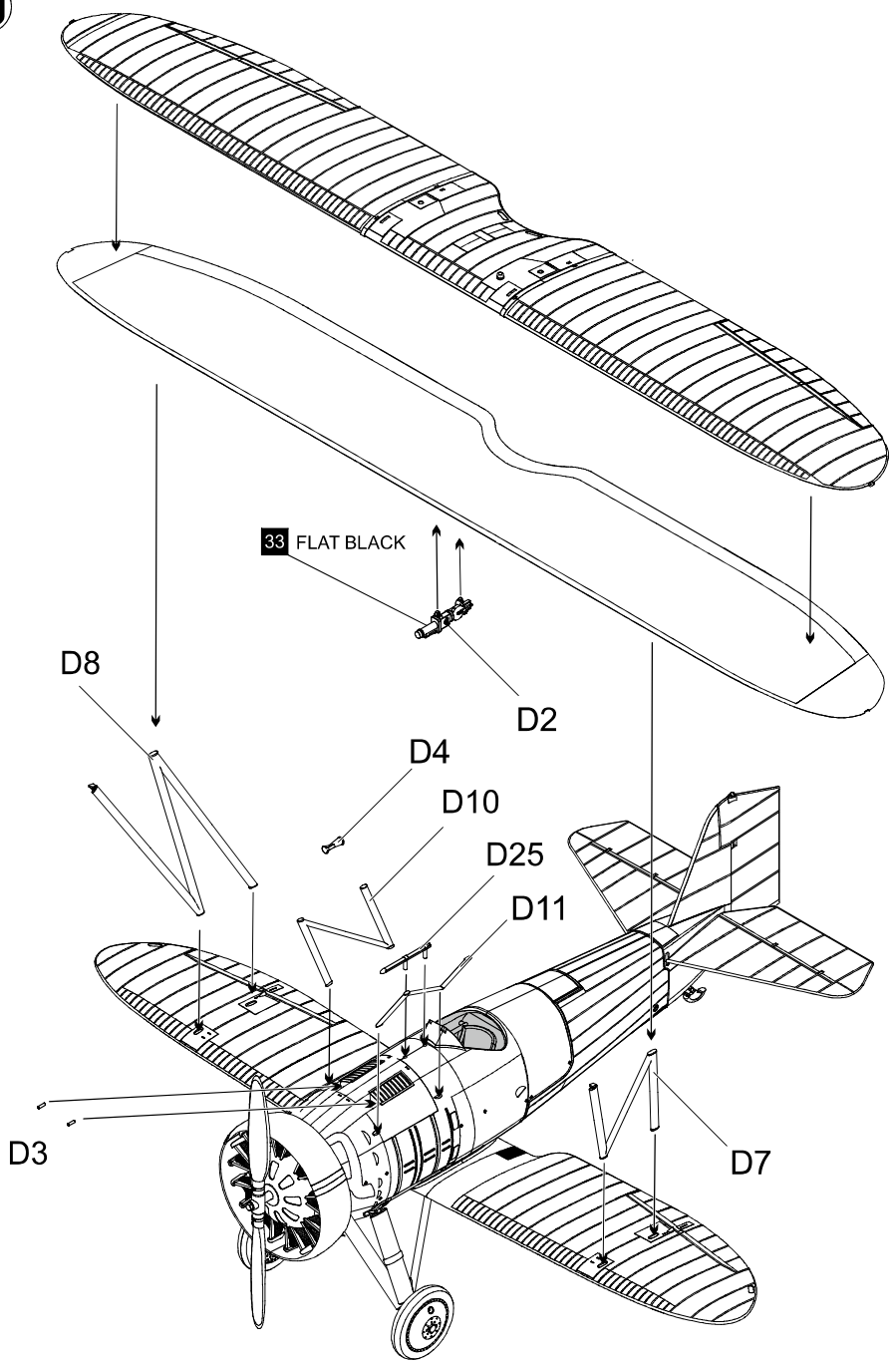

11

Nakajima A2N2 biplane wire bracing system

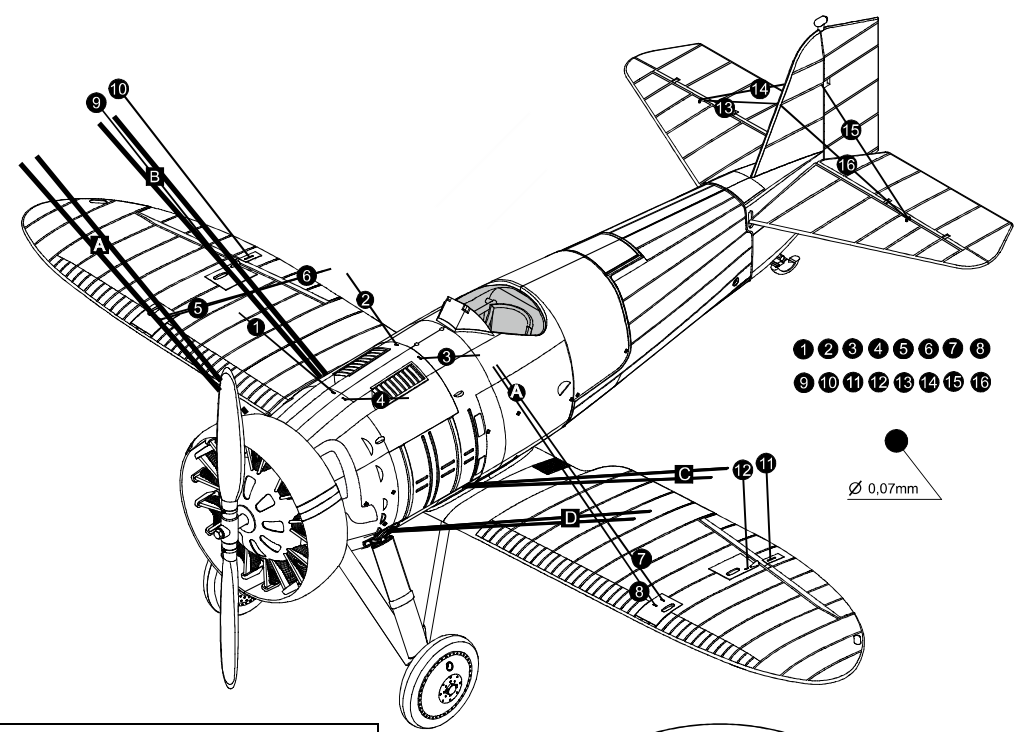

A B C D

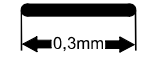

Interplane bracing struts
Ribbon for embroidery



SULKY 250YD

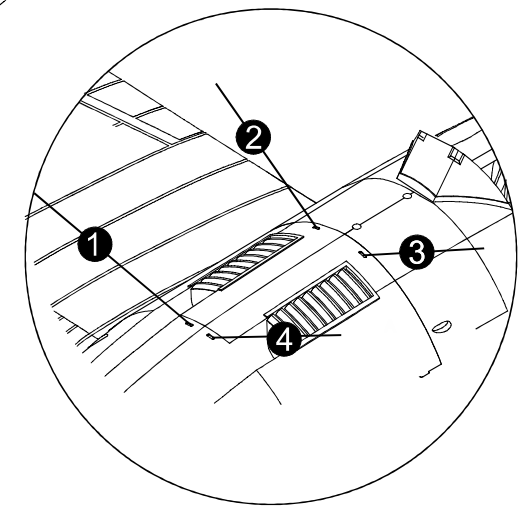

Centre-section bracing struts

12

Nakajima A2N2 biplane wire bracing system

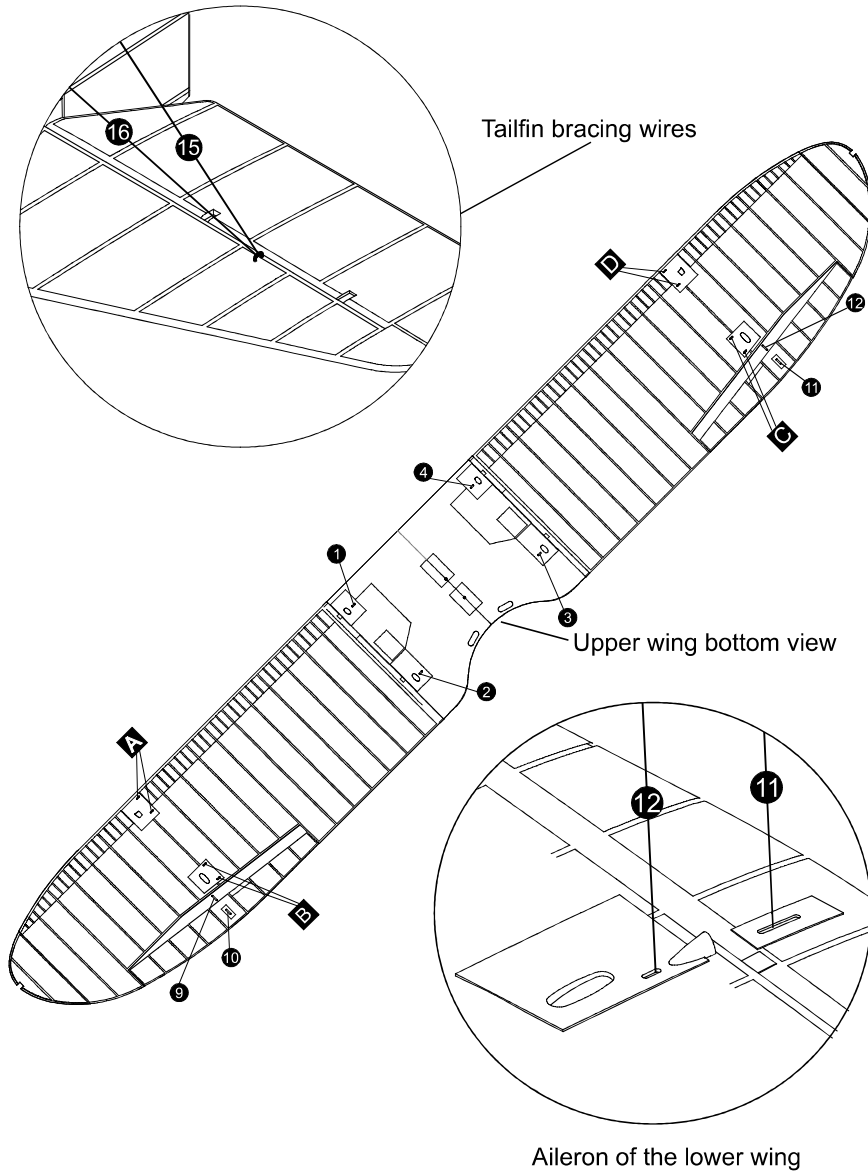

13

Options for experienced modelers: separate winglets

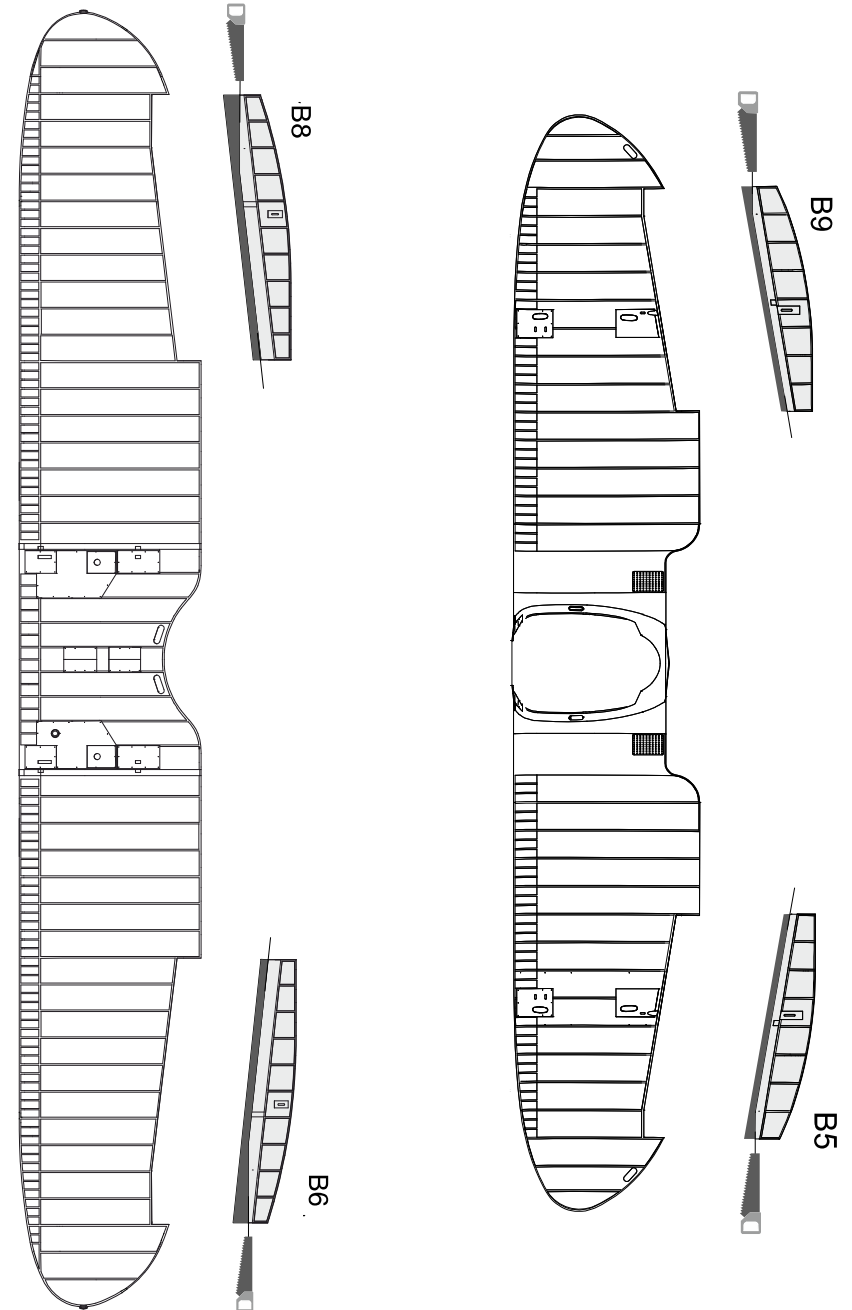

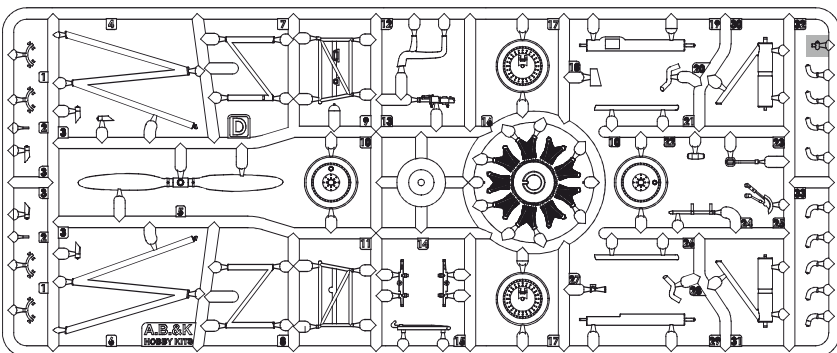
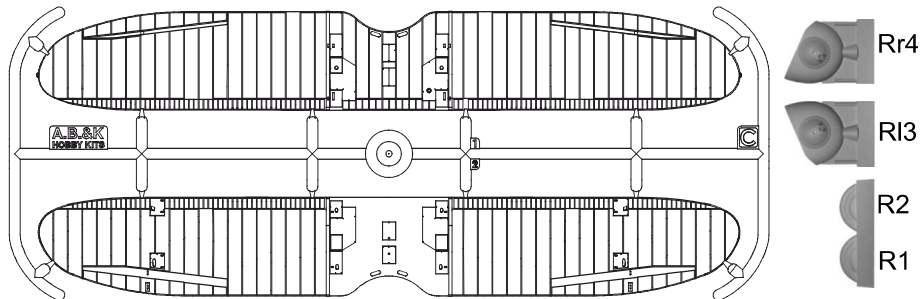
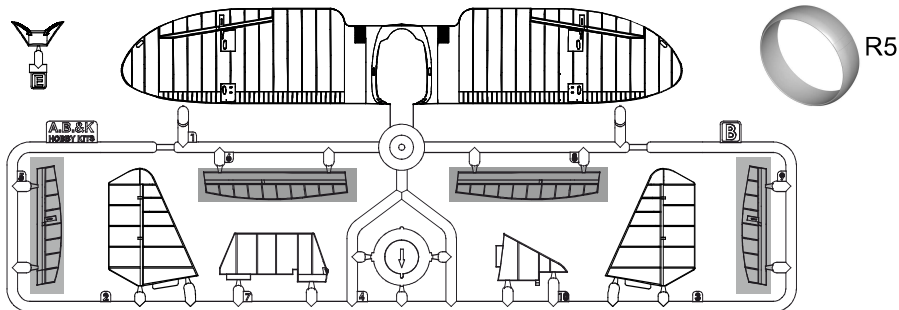
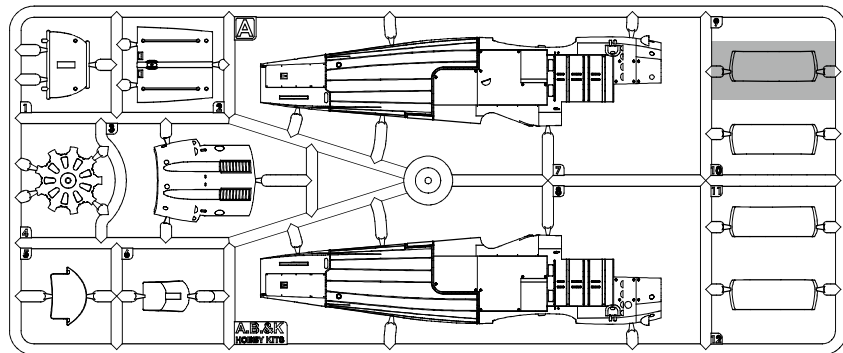

	Color name	GSI Mr.Color	AK-Interactive
1	WHITE	C1	RC004
2	BLACK	C2	AK471
3	RED	C3	RC005
8	SILVER	C8	AK478
33	FLAT BLACK	C33	RC001
47	CLEAR RED	C47	RC503
50	CLEAR BLUE	C50	RC504
57	METALIC BLUEGREEN	C57	AK 11898
61	BURNT IRON	C61	AK 485

Recommended accessories

Interior and exterior set for Nakajima A2N2 or A2N3

